



## Mk3 Cranked Window Handle



Agrément Certificate  
15/5204  
Product Sheet 1

### PRODUCT DESCRIPTION

Our Quantum MK3 Cranked Window Handle features an ergonomic design that ensures maximum hand clearance in operation. Part of our perfectly suited range of window and door hardware, making Quantum the perfect choice for all casement windows. With a 10 year mechanical & surface guarantee our handles are both durable and reliable.

### FEATURES & BENEFITS

- Elegant ergonomic design with superior aesthetics
- Designed to give maximum clearance in operation
- Part of the fully suited Quantum Range
- Clip fit screw covercaps
- Colour coded packaging for easy identification
- Supplied with screws, key & non-locking inserts
- Nine finishes available; White, Black, Chrome, Gold, Satin, Silver, Flint, Tungsten, Anthracite Grey and Antique Black
- 10 Year mechanical & 2 Year surface guarantee
- Coating tested to BS.EN: 2007 Grade 4
- Secured by Design accredited

# SPECIFICATION DATABASE



HWHC - 7/24 - V1.0

**Royale**  
Collection

## Mk3 Cranked Window Handle

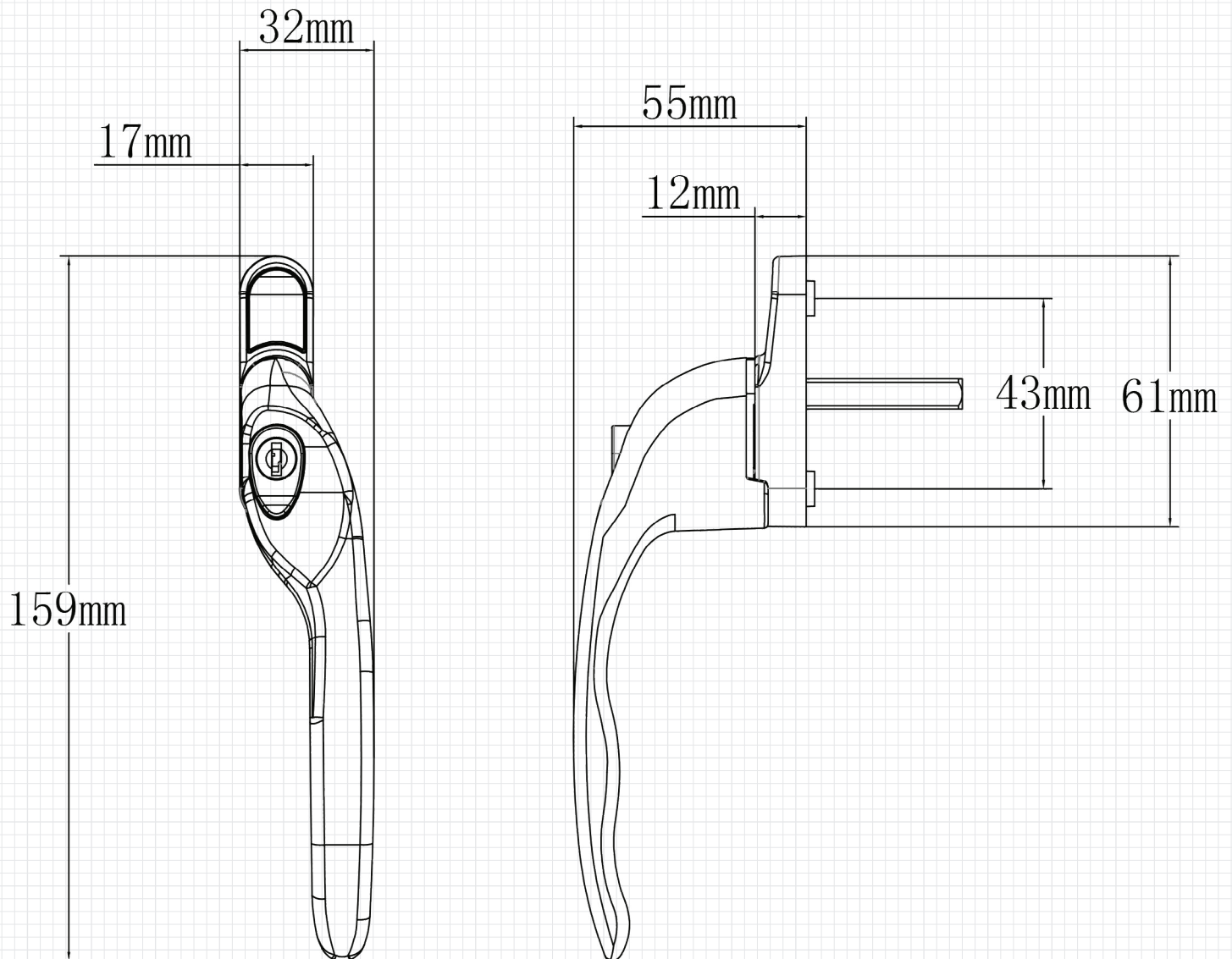

### PACKAGING

Individually bagged with screws, covercap, key and non-locking insert. Inner boxes of 10 and outer boxes of 80

### MAINTENANCE

To maintain a high quality appearance and operation we recommend that all external hardware is cleaned routinely, and moving parts are lightly lubricated a minimum of twice a year. Products used within a 1 mile radius of coastal areas, building sites or large industrial areas, more regular cleaning will be required to prevent build up of corrosive contaminants.